

Omnidirectional Dual-Reflector Shaping by Concatenating Conic Sections

Fernando J. S. Moreira* and José R. Bergmann†

*Dept. Electronics Engineering, Federal University of Minas Gerais
Av. Pres. Antonio Carlos 6627, Belo Horizonte, MG, CEP 31270-901, Brazil
fernandomoreira@ufmg.br

†CETUC, PUC-Rio
Rua Marques de São Vicente 225, Rio de Janeiro, RJ, CEP 22453-900, Brazil
bergmann@cetuc.puc-rio.br

Abstract— This work presents the shaping of axis-symmetric omnidirectional dual-reflector antennas. The shaping procedure is based on the consecutive concatenation of conic sections, in order to provide a uniform phase distribution together with a prescribed amplitude distribution over the antenna cylindrical aperture under geometrical optics (GO) principles. To illustrate the shaping procedure, an axis-displaced Cassegrain is designed to provide a uniform aperture illumination. The GO shaping results are validated using accurate method-of-moments analysis.

I. INTRODUCTION

A procedure for the geometrical-optics (GO) shaping of circularly symmetric dual-reflector antennas based on the concatenation of conic sections has been presented recently [1]. It improves traditional methods, as no ordinary differential equation must be solved. However, a rectangular coordinate system was adopted to describe the local conic sections. For that reason, the one-step procedure of [1] is based on a nonlinear algebraic equation, which was approximated to provide simple iterative solution. Here we improve the procedure by using polar coordinates to represent the local conic sections. This renders a one-step iterative procedure with linear algebraic equations. Besides, we extend the formulation to the shaping of omnidirectional configurations with broad-side radiation patterns.

II. SHAPING EQUATIONS

The local conic section S_n describing the subreflector has two foci (see Figs. 1 and 2). One is always at the origin (O), where the feed phase-center is located. Another is at P_n , which is also the focus of the parabola section (M_n) that generates the corresponding portion of the main reflector. The parabola axis, passing through P_n , is always perpendicular to the symmetry axis (z axis) of both reflectors, such that all main-reflector rays arrive parallel to each other at the antenna cylindrical aperture, providing a uniform phase distribution according to GO. Another GO principle used to define the conic sections is that the energy contained in the bundle of rays departing from O and intercepting the conic section S_n is conserved at the antenna aperture after being reflected by the local main-reflector parabola M_n . In order to uniquely define S_n and M_n , four parameters must be determined: the focal distance F_n of M_n , the interfocal distance $2c_n$ and the eccentricity e_n of S_n , and the tilt angle β_n of the S_n axis (see Fig. 2).

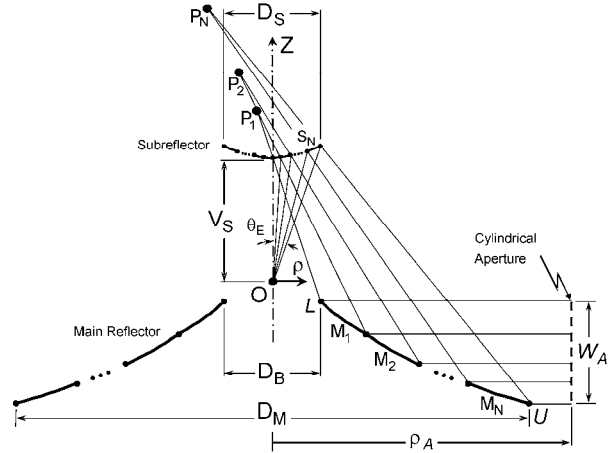

Fig. 1 Consecutive conic sections generating the omnidirectional ADC dual-reflector system

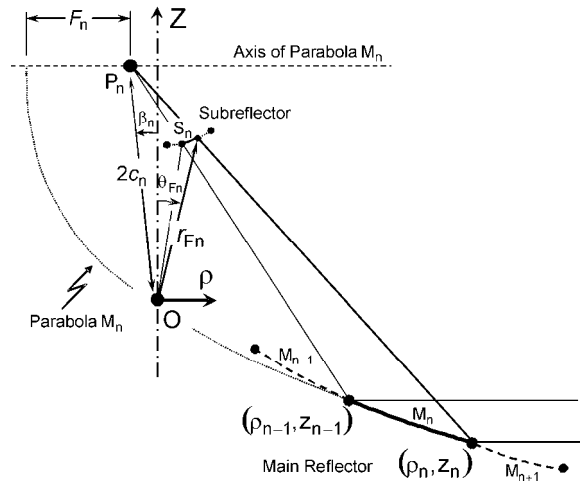

Fig. 2 Local conic-section parameters

From the polar equation of S_n one obtains:

$$r_{F_{n-1}} = \frac{a_n}{b_n \cos \theta_{F_{n-1}} + d_n \sin \theta_{F_{n-1}} - 1} \quad (1)$$

where

$$\begin{aligned} a_n &= c_n(e_n + 1/e_n) \\ b_n &= e_n \cos \beta_n \\ d_n &= e_n \sin \beta_n \end{aligned}$$

θ_F is the feed ray direction with respect to the z axis and r_F is the distance from O to S_n along the direction θ_F (see Fig. 2). In (1) the subscript $n-1$ indicates that the values of r_F and θ_F are those obtained in the previous iteration.

The iterative process starts at $n = 0$ with $\theta_{F0} = 0$ and $r_{F0} = V_S$, where V_S is the desired distance between the feed phase-center and the subreflector apex (see Fig. 1). The variable θ_{Fn} controls the steps of the shaping iterative procedure and is uniformly varied from $\theta_{F0} = 0$ to the subreflector edge at $\theta_{Fn} = \theta_E$, such that $\Delta\theta_F = \theta_{Fn} - \theta_{Fn-1} = \theta_E/N$. In principle, the accuracy of the shaping procedure is increased by decreasing $\Delta\theta_F$.

The second shaping equation is obtained by enforcing a constant path length ℓ_o from O (i.e., from the feed phase center) to the dual-reflector cylindrical aperture (at $\rho = \rho_A$, as illustrated in Fig. 1) to ensure a uniform phase distribution. From the polar equations of S_n and M_n one can show that

$$\ell_o = \rho_A + \frac{2c_n}{e_n} + 2F_n - 2c_n \sin \beta_n \quad (2)$$

The constant path length ℓ_o and ρ_A must be specified *a priori*. The remaining equations are obtained from the conservation of energy and from the mapping relation between the feed ray direction θ_F and the aperture coordinate z , which is equal to the z -coordinate of the main reflector. One can show that the relation between θ_F and z is given by [2]:

$$\frac{z_n}{\ell_o} = \frac{1 + d_n - b_n + \frac{2a_n}{\ell_o} - \left(1 + d_n + b_n + \frac{2a_n}{\ell_o}\right) \tan\left(\frac{\theta_{Fn}}{2}\right)}{1 + d_n + b_n + (1 + d_n - b_n) \tan\left(\frac{\theta_{Fn}}{2}\right)} \quad (3)$$

From (3) at $\theta_F = \theta_{Fn-1}$ one obtains the third equation:

$$\frac{z_{n-1}}{\ell_o} = \frac{1 + d_n - b_n + \frac{2a_n}{\ell_o} - \left(1 + d_n + b_n + \frac{2a_n}{\ell_o}\right) \tan\left(\frac{\theta_{Fn-1}}{2}\right)}{1 + d_n + b_n + (1 + d_n - b_n) \tan\left(\frac{\theta_{Fn-1}}{2}\right)} \quad (4)$$

where z_{n-1} is known from the previous iteration (Fig. 2).

In order to use (3) as the forth shaping equation, one must obtain the new coordinate z_n of the main reflector. This is accomplished by applying the conservation of energy along the tube of rays, described by the integral

$$\int_0^{\theta_{Fn}} G_F(\theta_F) r_F^2 \sin \theta_F d\theta_F = N_F \int_{z_n}^{z_U} G_A(z) \rho_A dz \quad (5)$$

where G_F is the circularly-symmetric radiated feed power density, G_A is the desired aperture power density, N_F is a normalization factor given by

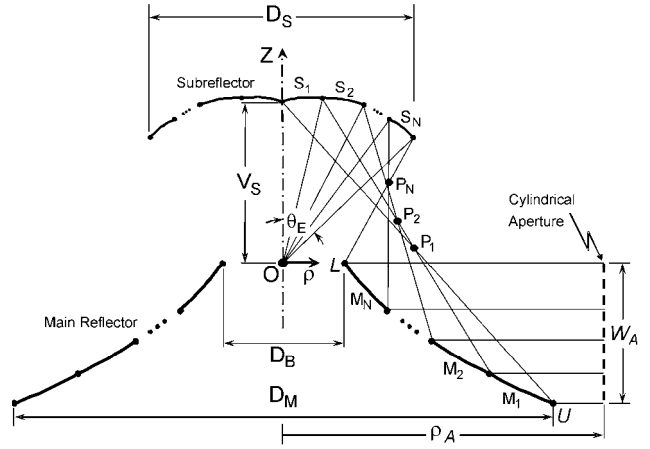

Fig. 3 Consecutive conic sections generating the omnidirectional ADE dual-reflector system

$$N_F = \int_0^{\theta_{Fn}} G_F(\theta_F) r_F^2 \sin \theta_F d\theta_F \Big/ \int_{z_U}^{z_L} G_A(z) \rho_A dz \quad (6)$$

and z_L and z_U are the z -coordinates of main-reflector edges L and U , respectively (see Fig. 1). Observe that $W_A = z_L - z_U$ is the width of the cylindrical aperture.

Substituting (1) and (2) into (3) and (4) one obtains a linear system of two equations involving b_n and d_n . Once the system is solved, the values of e_n and β_n are immediately obtained. Finally, the values of $2c_n$ and F_n are obtained from (1) and (2), respectively. With the conic parameters determined, the subreflector point at $\theta_F = \theta_{Fn}$ is located by the vector

$$\vec{r}_{Fn} = r_{Fn} (\cos \theta_{Fn} \hat{z} + \sin \theta_{Fn} \hat{\rho}) \quad (7)$$

where r_{Fn} is given by (1) with θ_{Fn-1} substituted by θ_{Fn} . The main-reflector point is located by the vector

$$z_n \hat{z} + \left[\frac{(z_n - 2c_n \cos \beta_n)^2}{4F_n} - F_n + 2c_n \sin \beta_n \right] \hat{\rho} \quad (8)$$

III. OTHER DUAL-REFLECTOR CONFIGURATIONS

The formulation presented in Sect. II assumes an ADC-like configuration [3], as depicted in Figs. 1 and 2. However, the procedure can be readily extended for other configurations [3]. For instance, a shaped ADE-like configuration is attained by changing the integration limits of (5):

$$\int_0^{\theta_{Fn}} G_F(\theta_F) r_F^2 \sin \theta_F d\theta_F = N_F \int_{z_U}^{z_n} G_A(z) \rho_A dz \quad (9)$$

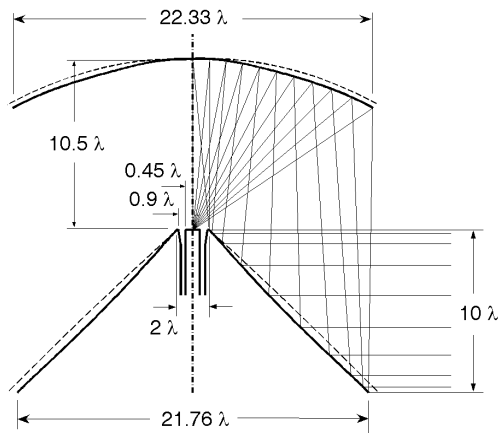

Fig. 4 Shaped (solid) and classical (dashed) ADC's

For the ADE-like configuration, the feed principal ray ($\theta_F = 0$) is reflected toward the main-reflector rim (at point U, as illustrated in Fig. 3) and the focal points of the conic sections lie between the sub- and main-reflectors.

IV. CASE STUDY

In order to validate the GO shaping algorithm, the ADC-like configuration of Sect. IV in [3] was synthesized. The reflector-shaping procedure departed from a classical ADC configuration (i.e., a dual-reflector system with both sub- and main-reflectors generated by single conic sections), designed with $V_S = 10.5\lambda$, $z_B = 0$, $W_A = 10\lambda$, $D_M = 23\lambda$, and $D_B = 2\lambda$ according to the procedure presented in [4]. These parameters further provided $D_S = 23\lambda$ and $\theta_E = 56.16^\circ$ for the initial classical configuration, which is illustrated with dashed lines in Fig. 4.

The reflector shaping was accomplished by the formulation presented in Sect. II. A uniform amplitude distribution (i.e., $G_A = \text{cte.}$) was specified for the GO field at the antenna cylindrical aperture, as in [3], Sect. IV. The feed model (G_F) was the same TEM coaxial-horn model adopted in [3]. To start the iterative procedure ($n = 0$), the shaped dual-reflector configuration (which is illustrated with solid lines in Fig. 4) was specified to coincide with the initial classical configuration along the feed principal ray (i.e., $r_{F0} = V_S = 10.5\lambda$, $z_0 = z_B = 0$, and $\ell_0 - \rho_A = V_S - D_B/2 + (V_S^2 + D_B^2/4)^{1/2} = 20.0475\lambda$).

The radiation pattern obtained by a method-of-moments analysis is in Fig. 5. The result is virtually the same obtained by the differential-equation shaping procedure discussed in [3], but with a much smaller numerical effort.

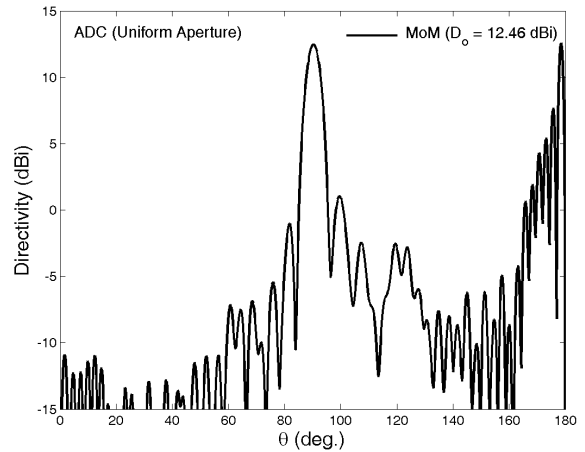

Fig. 5 Radiation pattern of the shaped ADC-like omnidirectional antenna

V. CONCLUSIONS

This work presented the shaping of axis-symmetric omnidirectional dual-reflector antennas based on the consecutive concatenation of conic sections. As no differential equation is numerically solved in the present procedure, the proposed technique is numerically efficient and converges rapidly. The formulation was derived for an ADC-like omnidirectional configuration, but can be readily extended to other configurations. To validate the shaping procedure, an ADC-like omnidirectional configuration was shaped to provide a uniform illumination at the antenna cylindrical aperture.

ACKNOWLEDGMENT

This work was supported in part by the Brazilian agencies CAPES, CNPq, FAPEMIG, and FAPERJ.

REFERENCES

- [1] Y. Kim and T.-H. Lee, "Shaped circularly symmetric dual reflector antennas by combining local conventional dual reflector systems," *IEEE Trans. Antennas Propagat.*, vol. 57, pp. 47–56, Jan. 2009.
- [2] B. S. Westcott, F. A. Stevens, and F. Brickell, "GO synthesis of offset dual reflectors," *IEE Proc.*, Pt. H, vol. 128, pp. 11–18, Feb. 1981.
- [3] F. J. S. Moreira, A. Prata, Jr., and J. R. Bergmann, "GO shaping of omnidirectional dual-reflector antennas for a prescribed equi-phase aperture field distribution," *IEEE Trans. Antennas Propagat.*, vol. 55, pp. 99–106, Jan. 2007.
- [4] F. J. S. Moreira and J. R. Bergmann, "Classical Axis-Displaced Dual-Reflector Antennas for Omnidirectional Coverage," *IEEE Trans. Antennas Propagat.*, vol. 53, no. 9, pp. 2799–2808, Sept. 2005.